



TO VIEW ALL THE  
INFORMATION AND  
BENEFITS OF OUR  
STORMCLEANSER™  
SCAN THE QR CODE



# STORMCLEANSER™

Factory-Fitted Installation Manual



INLET

**MC**  
fpmccann



**MC**  
fpmccann



# INTRODUCTION

---

This document provides a comprehensive guide to installation of a StormCleanser™ unit on site. It covers the case where the internal components are pre-fitted in the factory. The schematic and instructions provided are to be followed carefully. Your local FP McCann Special Products office should be contacted in case of any doubt, discrepancy, or installation issues.

# CONTENTS

---

Product Description	5
Models	6
Installation	7
- Inspection	7
- Preparation	8
- Materials & Equipment	8
- Procedure	9
Appendix-I: Stormcleanser™ Factory-Fitted Drawing	19
Appendix-II: General Jointing Guidelines	20

**PLEASE CONTACT A LOCAL FP MCCANN SPECIALIST ENGINEER OR HEAD OFFICE ON 028 7964 2558 IN CASE OF ANY DOUBT OR INSTALLATION RELATED ISSUES.**

# STORMCLEANSER™

## Factory-Fitted Installation Manual

---

### FIGURES

Figure 1 - StormCleanser™ Assembly and Exploded View	5
Figure 2 - StormCleanser™ main unit on trailer	8
Figure 3 - Typical StormCleanser™ assembly and build up components	9
Figure 4 - StormCleanser™ assembly top-level sections	10
Figure 5 - Step 1(a): Base Unit lowered into the excavated pit, using appropriate lifting equipment and method	11
Figure 6 - Step 1(b) - Butyl rubber seal installation on the Base Unit top face	11
Figure 7 - Butyl rubber seal installed and utility lifting anchors filled	12
Figure 8 - StormCleanser Main Unit lifted and joined with the Base unit in the pit. Main unit to be lifted using a spreader bar or lifting chains with edge protection.	12
Figure 9 - Site image: Main unit lifted using provided spherical anchors, with edge protection (right)	13
Figure 10 - Installation so far: Main and Base unit connected in the pit	13
Figure 11 - Push the pipes in from sides and use grout/glue to make up the connection	14
Figure 12 - Main unit with butyl rubber seal installed, ready for cover/access assembly configuration	14
Figure 13 - Installation so far: Main and Base unit with pipe connections and butyl rubber seal, ready for cover/access assembly completion	15
Figure 14 - Lift and place the cover/access assembly to cover level and join the makeup ring(s), slab, seating rings, and lid	16
Figure 15 - Site image of cover slab lifting and placement	16
Figure 16 - StormCleanser™ unit assembled and back filled, prior to final backfill	17
Figure 17 - Fully Installed StormCleanser™	18

# STORMCLEANSER™

## Factory-Fitted Installation Manual

### PRODUCT DESCRIPTION

StormCleanser™ provides a cost-effective solution for designers, engineers and contractors involved in the provision of Sustainable Drainage Systems (SuDS). This unit has no moving parts, requires no power, and is constructed within standard precast concrete chambers.

The units come factory fitted in precast chambers and can also be installed on-site as required. The modular stainless steel built assembly is designed to provide installation simplicity. The separator internal assembly is fabricated out of stainless steel (304L/316L), per BSI BS EN 10088-2-2014. Stainless Steel material grade and composition, provides exceptional longevity due to high corrosion resistance. The lifespan of the internal assembly outlasts the lifespan of a typical precast concrete structure (100+ years).



Figure 1 - StormCleanser™ Assembly and Exploded View

# STORMCLEANSER™

## Factory-Fitted Installation Manual

The generic configuration of the StormCleanser™ consists of the following main components:

- Inlet Sub-Assembly
- Core Sub-Assembly
- Catch Skirt
- Sump/Base Unit

### INLET SUB-ASSEMBLY:

The internal assembly comprises of the main components diverting the flow tangentially, at an angular velocity designed to be most conducive to separation of sediment particles. The inlet assembly also enables the StormCleanser™ to be configured for different inlet angles with respect to the outlet pipe, ranging from 90° – 270°. Moreover, multiple inlet sub-assemblies could also be stacked to form a multiple inlet configuration of StormCleanser™.

### CORE SUB-ASSEMBLY:

The sub-assembly consists of a circular core that provides an annular separation zone as well as an outlet channel that discharges the treated water out of the system. It also consists of the structural mounting surfaces to enable steadfast and safe installation.

### CATCH SKIRT:

The Catch Skirt, also known as sump tray or baffle plate, minimizes the resuspension as well as escape of the captured sediment. The Catch Skirt also hydrodynamically directs the flow vortices towards the sump region.

### SUMP/BASE UNIT:

The sump or catchment zone is the solids or denser sediment storage region. The separated particles are retained in the sump until cleaned during the maintenance process.

The combination of the discharge rate from surface runoff and the target pollutant load are the key variables governing the diameter of the separator and the height of the base unit respectively. These two values are determined by the designer as per the individual site requirements.

## MODELS

Table 1 provides an overview of standard StormCleanser™ units.

Table 1 - StormCleanser™ Standard Sizes

MODEL	TANK DIAMETER	MAX TREATMENT FLOW RATE	PIPE SIZE	MIN. SEDIMENT STORAGE CAPACITY	MIN. OIL STORAGE CAPACITY	MAX. HEAD LOSS AT TREATMENT FLOW RATE
	(mm)	(L/s)	(mm)	(m³)	(L)	(mm)
PRE-SC900	900	25	150	0.28	150	120
PRE-SC1050	1050	33	225	0.39	238	180
PRE-SC1200	1200	43	300	0.50	320	240
PRE-SC1500	1500	67	375	0.82	630	300
PRE-SC1800	1800	96	450	1.23	1085	360
PRE-SC2100	2100	131	525	1.75	1725	420
PRE-SC2400	2400	172	600	2.38	2575	480
PRE-SC2700	2700	217	675	3.13	3670	540
PRE-SC3000	3000	268	750	4.01	5035	600
PRE-SC3600	3600	387	900	6.20	8703	720
PRE-SC4000	4000	477	900	8.00	11938	800

Notes: Sediment storage capacity could be extended as required, per the desired maintenance frequency

# STORMCLEANSER™

## Factory-Fitted Installation Manual

---

### INSTALLATION

StormCleanser™ could be provided both as factory-fitted in wide-wall manhole rings or monolithic chambers. Moreover, it could also be installed on-site via modular sub-assembly units. The angle adjustment capability provides tolerance and freedom of movement to achieve appropriate drainage design orientation. The modular assembly design of the StormCleanser™ enables convenient fitting by simply stacking the inlet(s) at the desired angle(s).

### INSPECTION

At the arrival of the unit on-site (Figure 2), below essential inspections are to be carried out. This would ensure efficient installation procedure as well as timely resolution of any potential issues.

- Any deviation or discrepancy from the approved general arrangement drawings shall be documented and notified
- Any minor repair to the unit shall be sent for pre-approval to the FP McCann Specials engineer
- In case of a factory-fitted unit, identify the Base (sump) unit and the Main (separator assembly) unit
- For Factory-Fitted installation type units, parts and sub-assemblies should be checked against the assembly drawing (Appendix-I)
- Fasteners quantity and type should be checked against the provided assembly drawing (Appendix-I)
- Note the size and weight of the factory-fitted or loose assembly units and sub-assemblies, to ensure lifting capacity
- Identify inlet(s) and outlet ports
- Identify appropriate lifting location markings

**IF A PART APPEARS DAMAGED, DURING INSPECTION OR PRIOR TO INSTALLATION, PLEASE CONTACT A REGIONAL FP MCCANN OFFICE IMMEDIATELY, FOR FURTHER INVESTIGATION.**

# STORMCLEANSER™

## Factory-Fitted Installation Manual



Figure 2 - StormCleanser™ main unit on trailer

### PREPARATION

The StormCleanser™ unit shall be stored in compliance with site safety regulations and in a safe environment. Below mentioned preliminary steps are required before committing to installation of the unit in the excavated pit. Installation pit should be excavated and ready prior to installation. The excavation should be per applicable construction standards of sub-base setup and bedding. The recommended base and bedding design and construction standards are per Sewers for Adoption 8th Edition – Sewer Sector Guidance, Appendix C.

- Excavate the installation pit per drainage design standards and guidelines
- Sub-base shall be sufficiently compacted, solid, and level
- Level and elevation should be measured and in compliance with the provided general arrangement drawing

### MATERIALS & EQUIPMENT

The following essential equipment would be required to perform the installation of the internal assembly on-site.

- Non-shrink grout, butyl rubber (or similar water proof seal), and flex-sealant
- Lifting equipment (Max. Weight capacity per the weight specified on the labels of the delivered unit)
- Lifting slings/chains and hooks, for both precast chamber spherical and utility anchors
- Pressure wash or cleaning equipment (if required)
- Access slab/lid hardware and tooling

For more information on lifters and lifting equipment, please visit

[HTTPS://FPMCCANN.CO.UK/RESOURCES/DOWNLOADS/KNOW-YOUR-LIFTERS/](https://fpmccann.co.uk/resources/downloads/KNOW-YOUR-LIFTERS/)

# STORMCLEANSER™

## Factory-Fitted Installation Manual

### PROCEDURE

Identify the sub-units of the factory-fitted FP McCann StormCleanser™ unit. The Main Unit comprises of two manhole/wide-wall rings glued in factory. The Base Unit is a manhole/wide-wall ring with a base. Lifting points are provided and marked for appropriate handling of the Main and Base Unit. Figure 3 and Figure 4 are illustrations of a standard StormCleanser™ unit. The configuration, sump depth, quantity and size of the unit as well as rings, access/cover level configurations may vary per required configuration/model and chamber build up requirements.

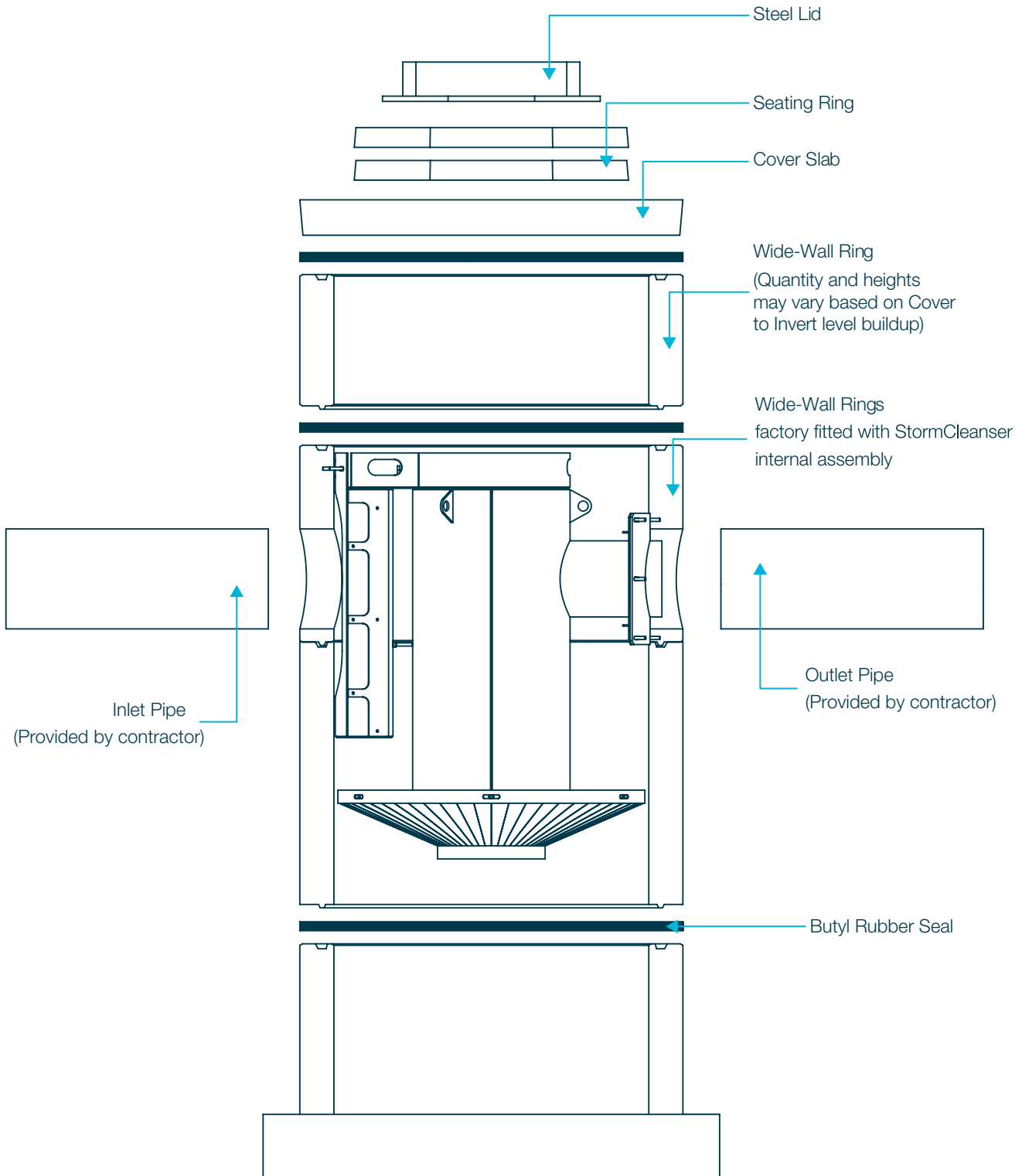

Figure 3 - Typical StormCleanser™ assembly and build up components

# STORMCLEANSER™

## Factory-Fitted Installation Manual

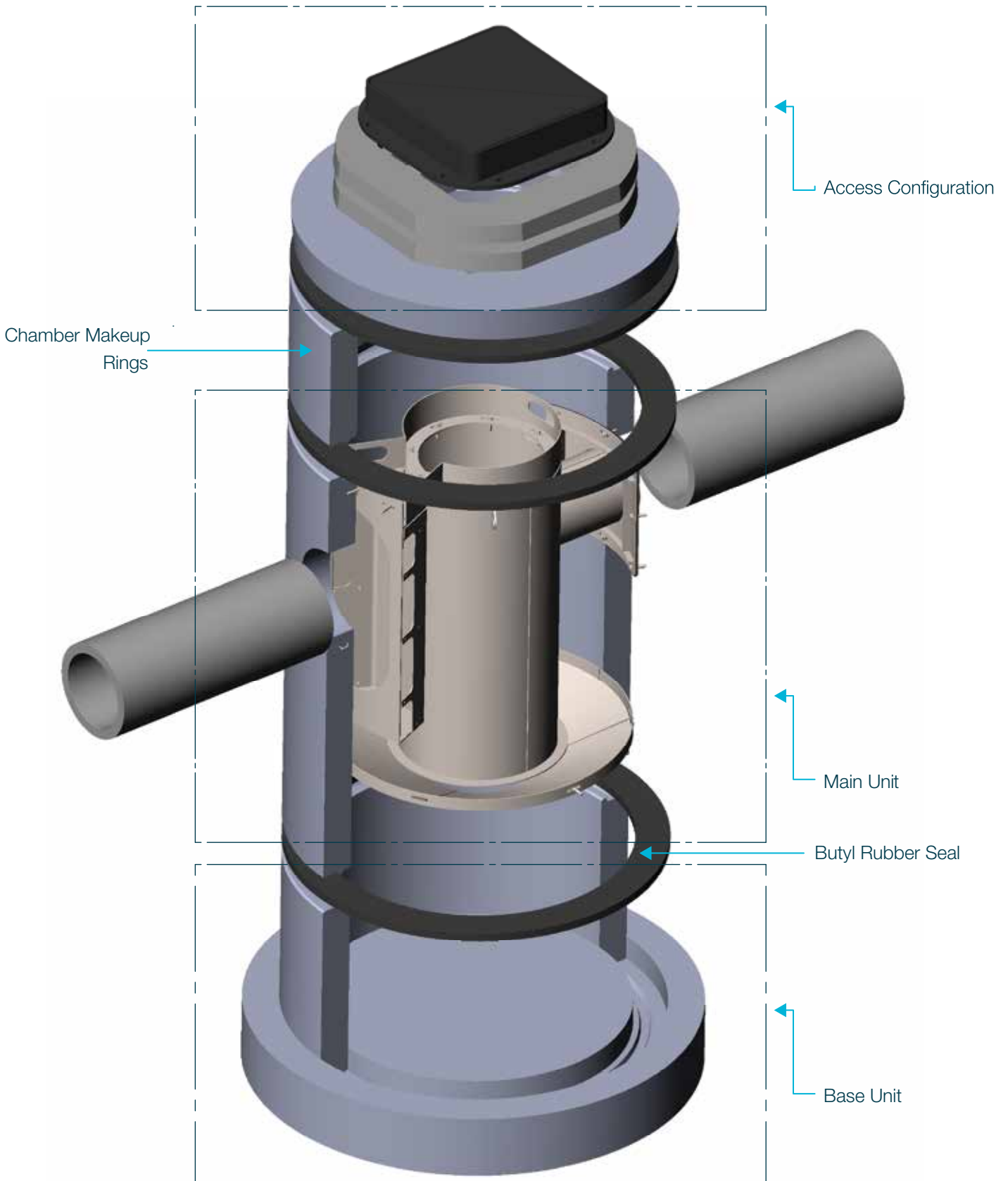

Figure 4 - StormCleanser™ assembly top-level sections

# STORMCLEANSER™

## Factory-Fitted Installation Manual

A STEP-BY-STEP GUIDE TO INSTALL THE FACTORY-FITTED UNIT IS PROVIDED IN THIS SECTION.

### STEP 1(A)

Lift and place the Base (Sump) Unit to the sub-base using appropriate lifting equipment and method. For lifting, only use the embedded utility anchors on the base (Figure 5).

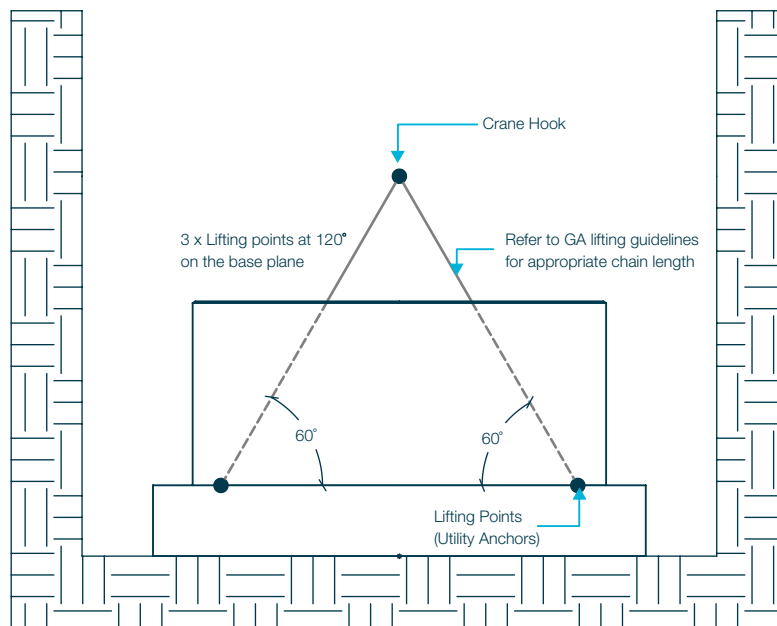

Figure 5 - Step 1(a): Base Unit lowered into the excavated pit, using appropriate lifting equipment and method

### STEP 1(B)

Install butyl rubber seal on the top groove profile (Figure 6 and Figure 7) of the Base Unit per manhole installation standards. Also, fill the utility anchors with appropriate grout/compound for a smooth and flat surface finish.

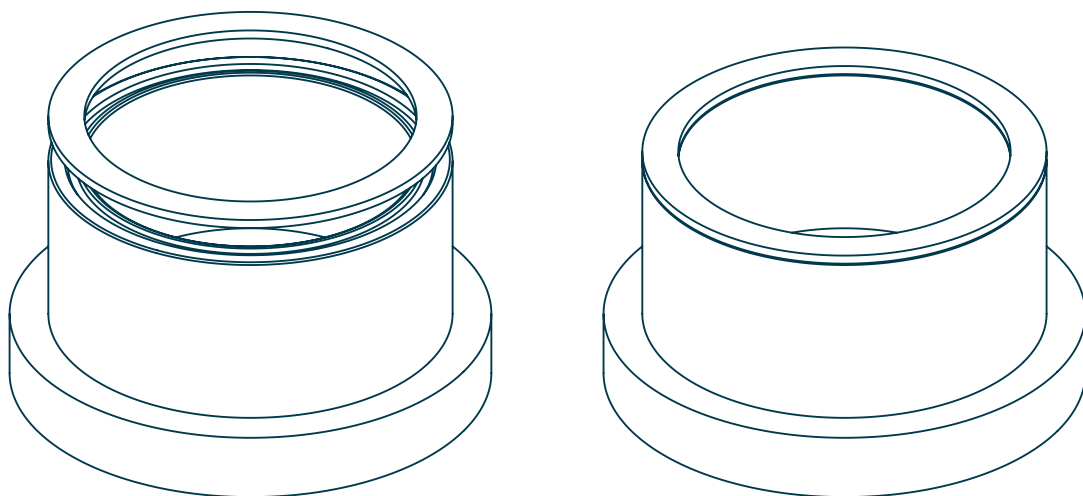

Figure 6 - Step 1(b) - Butyl rubber seal installation on the Base Unit top face

# STORMCLEANSER™

## Factory-Fitted Installation Manual



Figure 7 - Butyl rubber seal installed and utility lifting anchors filled

### STEP 2

Lift the StormCleanser™ Main Unit using the casted spherical anchor elements on the wall (Figure 8 and Figure 9). The Main Unit should be lifted using either a spreader bar assembly or appropriate chains, however employ shims for chamber edge protection (Figure 9).

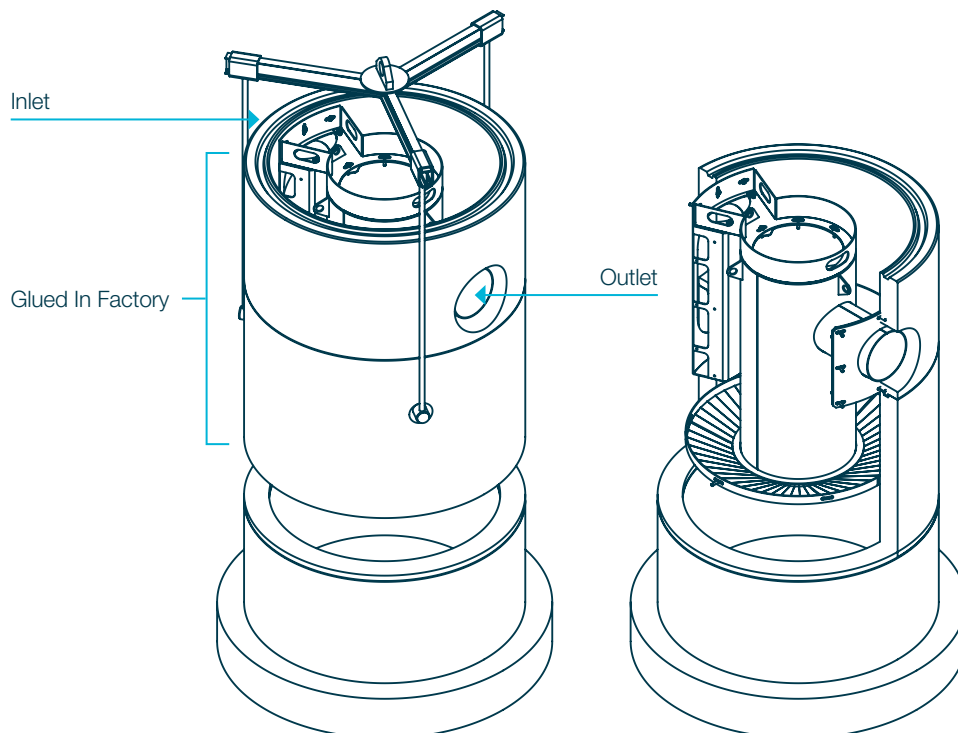

Figure 8 - StormCleanser Main Unit lifted and joined with the Base unit in the pit. Main unit to be lifted using a spreader bar or lifting chains with edge protection

# STORMCLEANSER™

## Factory-Fitted Installation Manual



Figure 9 - Site image: Main unit lifted using provided spherical anchors, with edge protection (right)

**DO NOT USE THE PAD-EYES ON THE STORMCLEANSER™ INTERNAL ASSEMBLY TO LIFT THE MAIN UNIT CHAMBER**

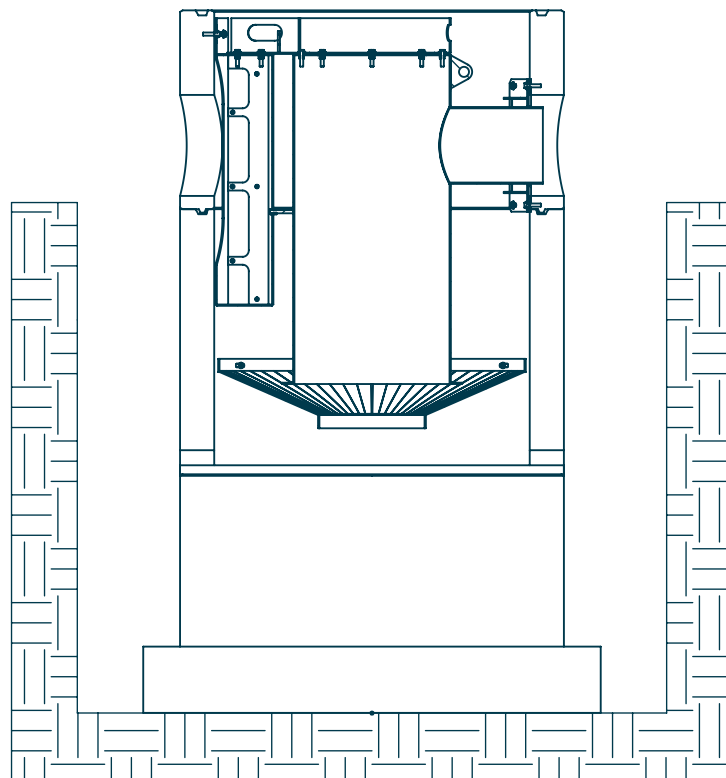

Figure 10 - Installation so far: Main and Base unit connected in the pit

Figure 10 shows a cross section of the Main and Base Unit assembly. Main unit orientation should be rechecked against the inlet and outlet pipes.

# STORMCLEANSER™

## Factory-Fitted Installation Manual

### STEP 3(A)

Push the pipes in to the provided inlet and outlet cored holes (Figure 11). If connector seals are incorporated or used, ensure that appropriate guidelines are followed per Appendix-II: General Jointing Guidelines. In case of no connector seals, pipes should be lined up, pushed in, and connection should be packed and made good, with appropriate joint sealant.

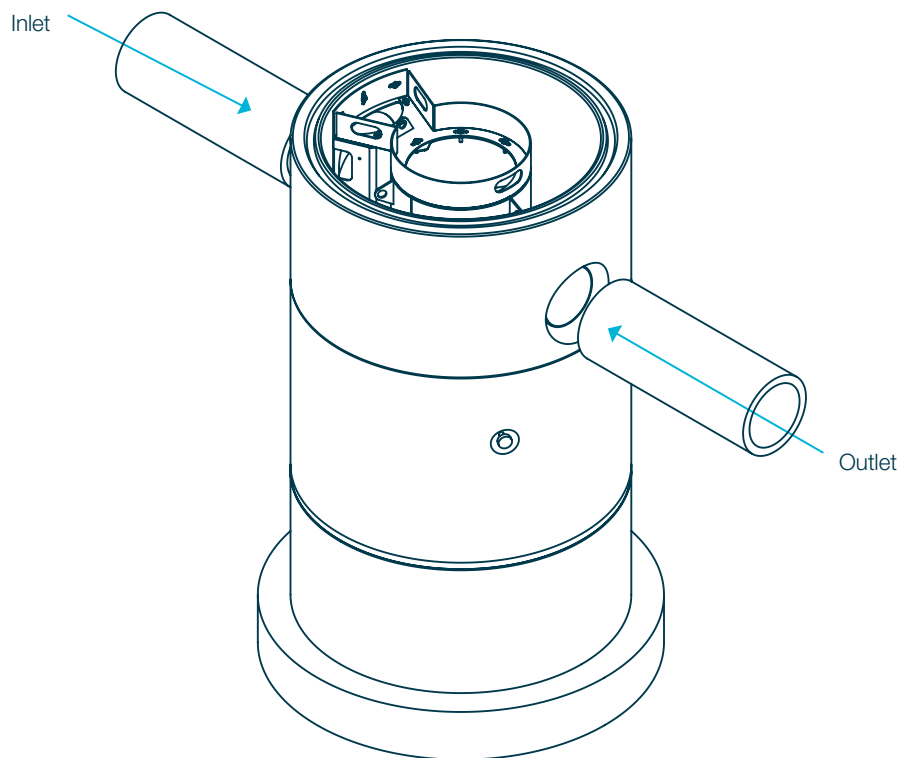

Figure 11 - Push the pipes in from sides and use grout/glue to make up the connection

### STEP 3(B)

Install butyl rubber seal on the top groove profile of the Main Unit, as shown in Figure 12.

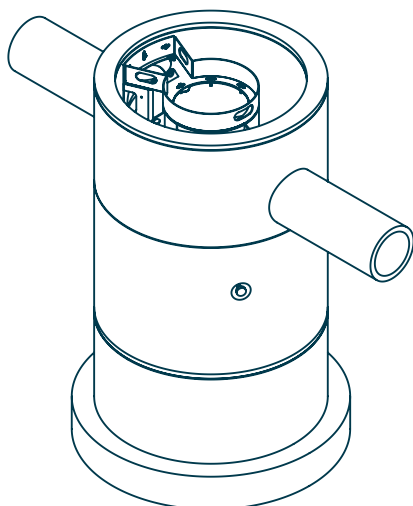
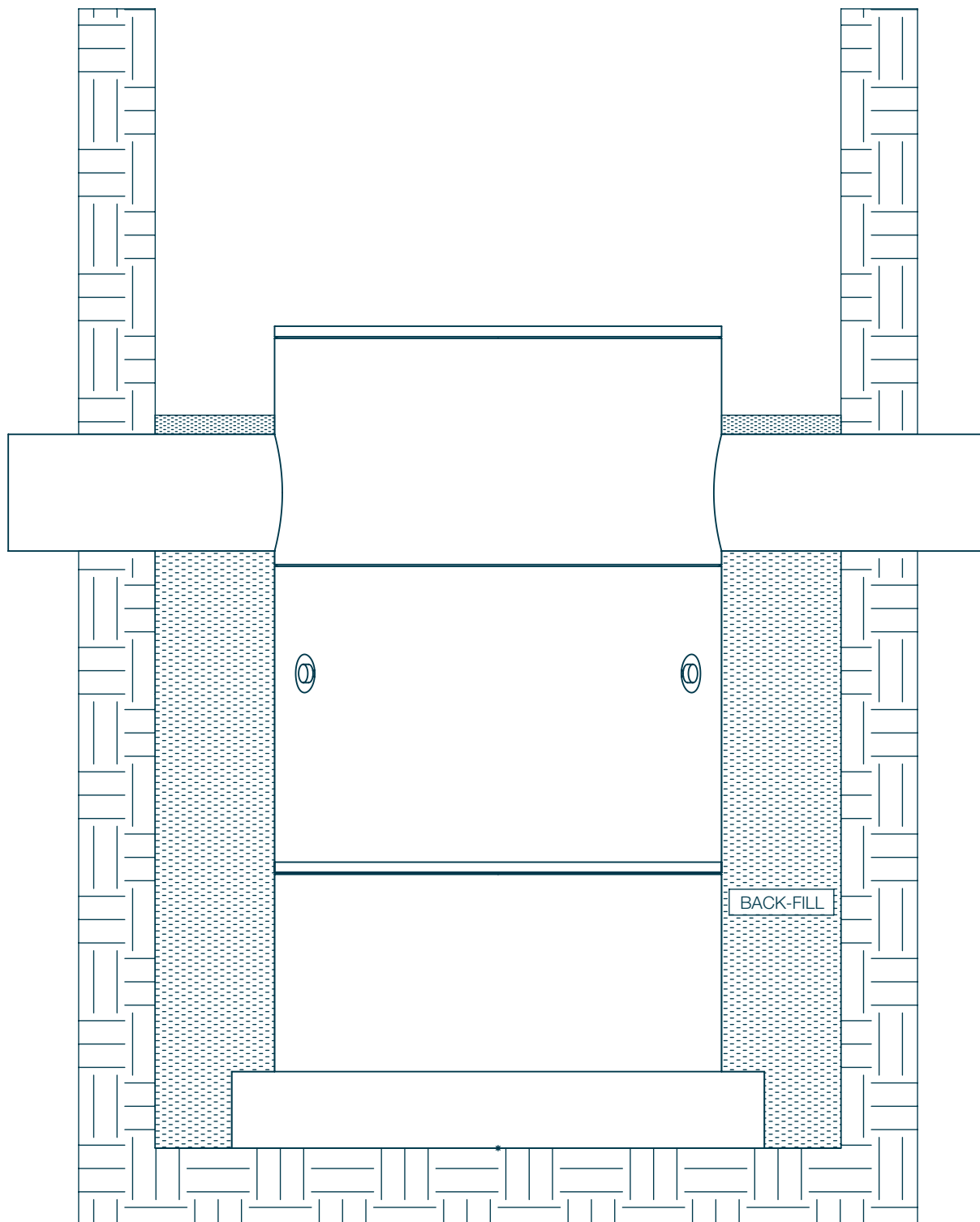

Figure 12 - Main unit with butyl rubber seal installed, ready for cover/access assembly configuration

# STORMCLEANSER™

## Factory-Fitted Installation Manual



*Figure 13 - Installation so far: Main and Base unit with pipe connections and butyl rubber seal, ready for cover/access assembly completion*

The StormCleanser™ assembly of Main Unit, Base Unit, and pipe connections (Figure 13) is now ready for invert to cover level make-up rings and cover/access assembly.

# STORMCLEANSER™

## Factory-Fitted Installation Manual

### STEP 4

Lift and place all the make-up wide-wall/manhole rings and seal using butyl rubber (Figure 14). Finally, lift and place the cover slab (Figure 15), seating rings, and steel lid. Grout is poured between seating rings and steel lid to set the components.

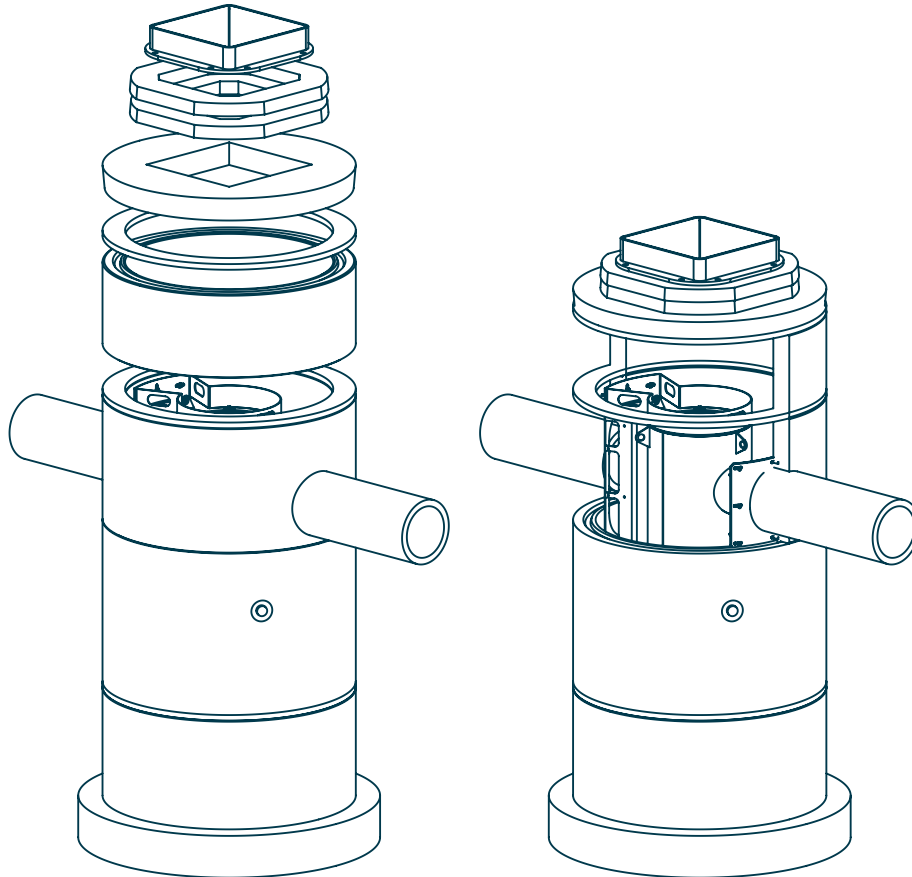

*Figure 14 - Lift and place the cover/access assembly to cover level and join the makeup ring(s), slab, seating rings, and lid*



*Figure 15 - Site image of cover slab lifting and placement*

The assembly is now complete (Figure 16) and ready for final inspection. Once inspected the excavation should be appropriately back-filled.

# STORMCLEANSER™

## Factory-Fitted Installation Manual

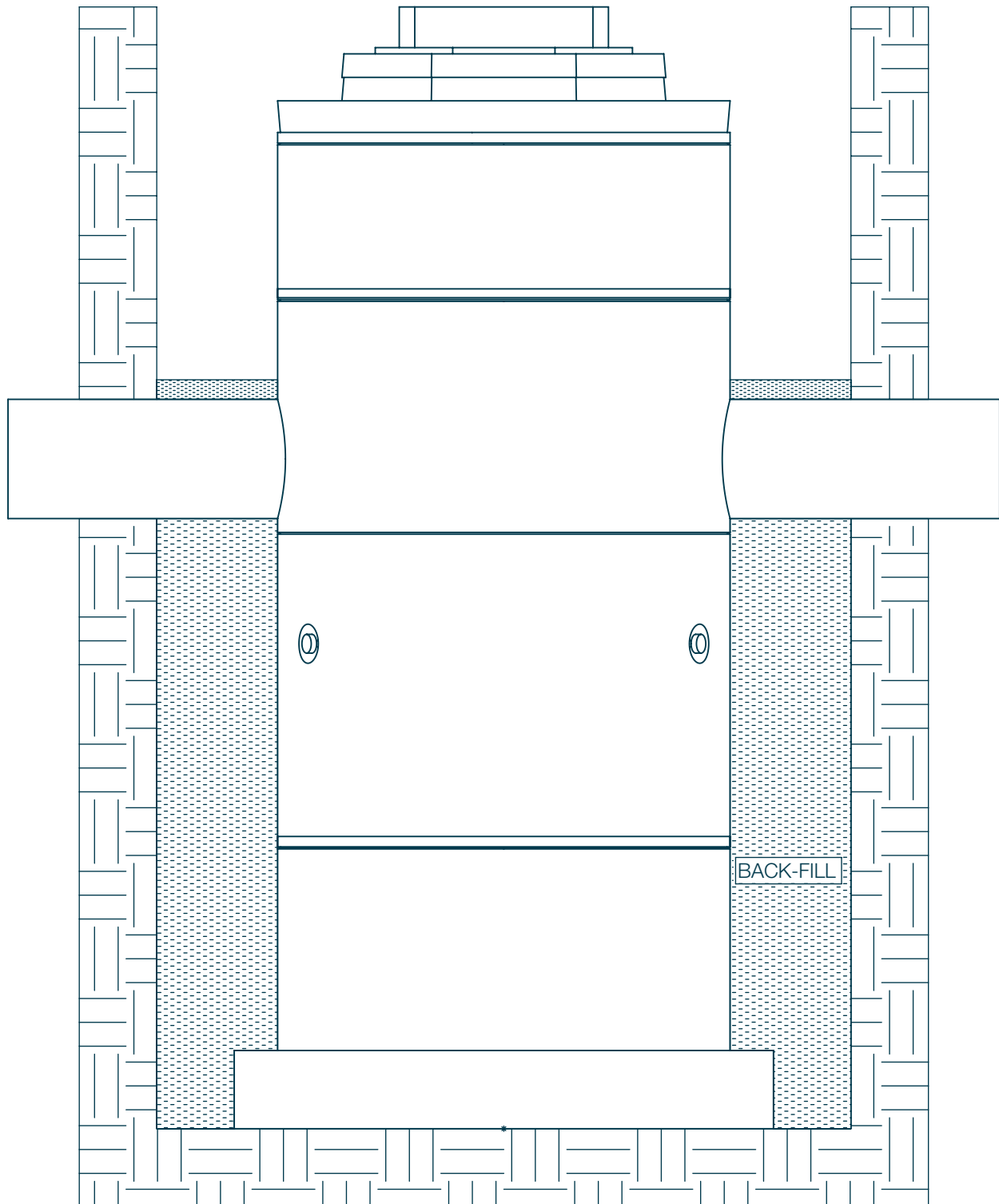

Figure 16 - StormCleanser™ unit assembled and back filled, prior to final backfill

The fully installed StormCleanser™ unit is shown in Figure 17. For future operation and maintenance guidelines, refer to the online O&M Manual.

# STORMCLEANSER™

## Factory-Fitted Installation Manual

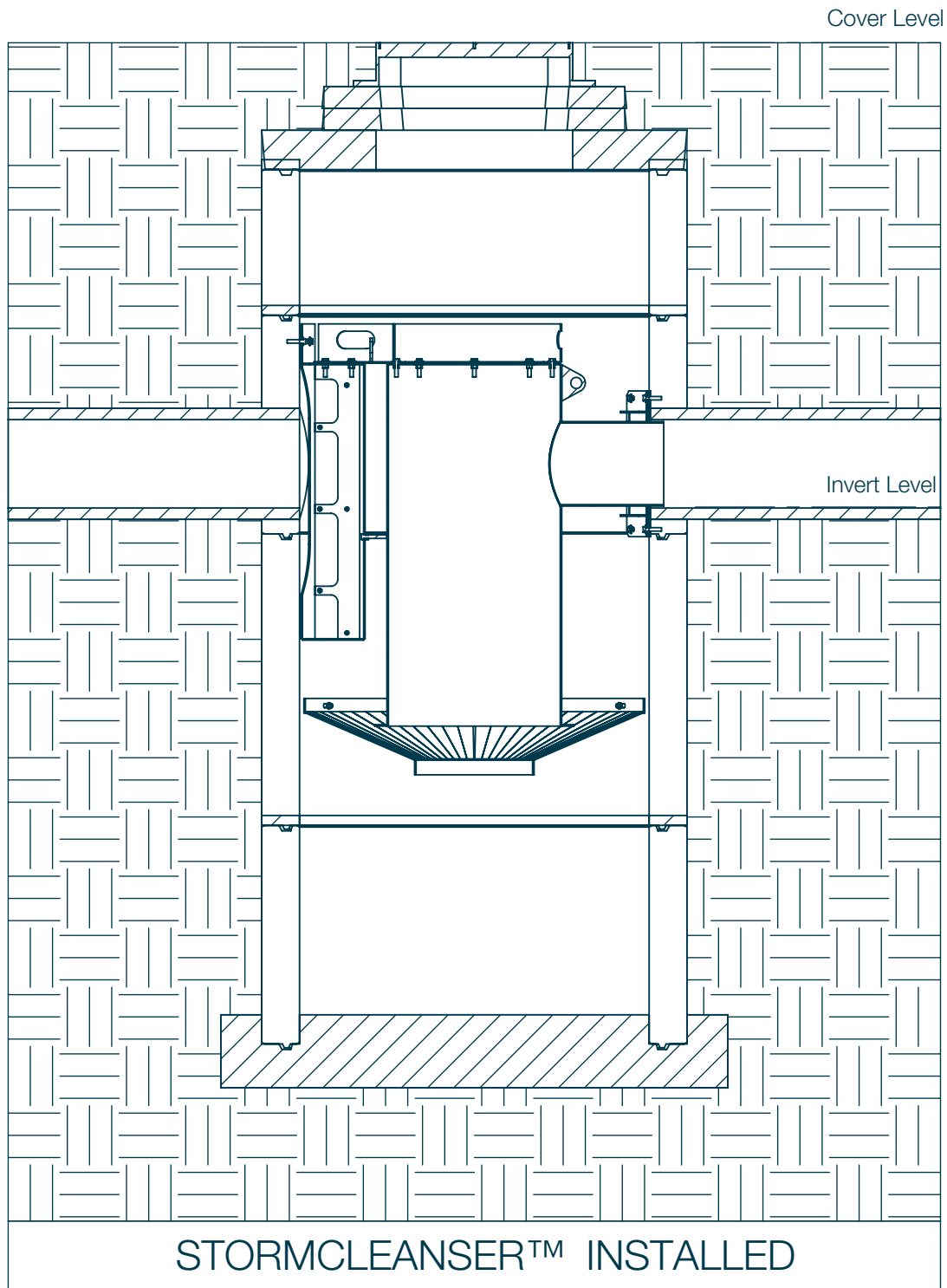

Figure 17 - Fully Installed StormCleanser™

**PLEASE CONTACT A LOCAL FP MCCANN SPECIALIST ENGINEER OR HEAD OFFICE ON 028 7964 2558 IN CASE OF ANY DOUBT OR INSTALLATION RELATED ISSUES.**



# STORMCLEANSER™

## Factory-Fitted Installation Manual

---

### APPENDIX-II: GENERAL JOINTING GUIDELINES

For better and efficient pipe jointing, below are highly recommended:

- Ensure that the rubber connector seal is in position at the inlet/outlet of the manhole base
- Pipe faces to be jointed should be square, chamfered and clear of any snags or sharp edges
- Lubricate the connecting pipe with an approved FP McCann lubricant
- Push the pipe squarely into the inlet/outlet seal until fully inserted (if mechanical means is required, ensure the end of the pipe is protected to avoid damage)
- Check that the seal is watertight and that the gradient and line of the pipe is acceptable.
- For ribbed pipes it is essential that the plastic pipe seal is fitted on the last rib of the pipe and that the pipe is lubricated prior to inserting it into the connector seal
- When jointing connections in cold weather, the connector seal should be brought back to temperature by placing in a site office or machine cabin. Warming the seals during cold conditions helps, especially during sub-zero temperatures or if the StormCleanser™ units have been stored with seals in for some time; warming the seals energises the rubber making the joint easier to make



TO VIEW ALL THE  
INFORMATION AND  
BENEFITS OF OUR  
STORMCLEANSER™  
SCAN THE QR CODE



## **AGRICULTURE**

Lydney 01594 847500 Grantham 01476 562277

## **ARCHITECTURAL PRECAST**

London 020 3905 7640

## **BOX CULVERTS**

Weston Underwood 01335 361269

## **BUILDING PRODUCTS**

Cadeby 01455 290780

## **DOCK LEVELLER PITS**

Weston Underwood 01335 361269

## **DRAINAGE**

Ellistown 01530 240000 (England/Wales) Magherafelt 028 7954 9026 (Scotland/NI)

## **FENCING**

Cadeby 01455 290780

## **FILTER BED SYSTEMS**

Littleport 01353 861416

## **FLOORING**

Weston Underwood 01335 361269 Uddingston 01698 803300 Magherafelt 028 7954 9026 (NI)

## **POWER & INFRASTRUCTURE**

Littleport 01353 861416

## **RAIL**

Littleport 01353 861416

## **SPECIALIST PRECAST**

Littleport 01353 861416

## **STRUCTURAL PRECAST**

Byley 01606 843500 Grantham 01476 562277

## **STORMTANK™ - TANKS & CHAMBERS**

Weston Underwood 01335 361269

## **TUNNELS & SHAFTS**

Cadeby 01455 290780

## **WALLING**

Grantham 01476 562277 Lydney 01594 847500  
Uddingston 01698 803 300 (Scotland) Magherafelt 028 7954 9026 (NI)

**FPMCCANN.CO.UK**