

T-Bolt installation system

MC
fpmccann

tunnels
& shafts

Tunnels & Shafts

FP McCann offers a wide range of Smoothbore Shaft Linings incorporating a proprietary fixing system for the horizontal and vertical connections between segments. Forged straight bolts and cast-in sockets connect the vertical joints with forged T bolts and cast in T boxes forming the horizontal connections.

Fixings may be either single or double row depending on shaft diameter

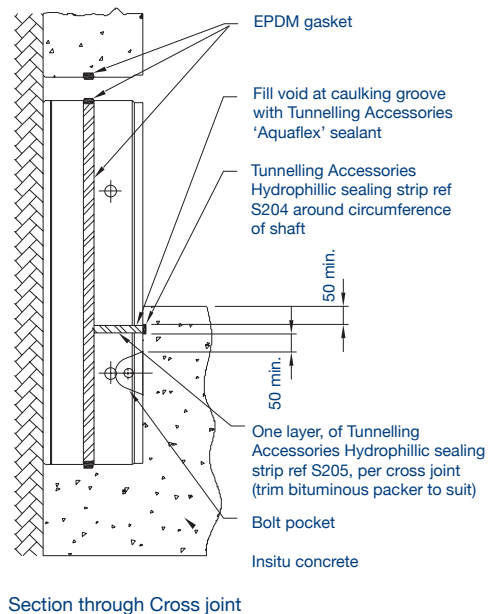
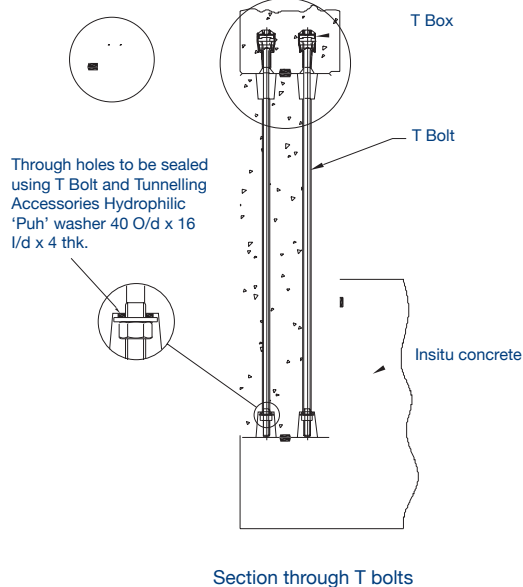

This innovative T Bolting system has been designed and developed to facilitate speedy installation while ensuring precise ring build and optimum gasket sealing performance.

Advantages over Screw-in System:

- Faster, more efficient means of shaft installation
- Improved accuracy of build
- Maintains shaft circularity

FP McCann has actively sought feedback from shaft sinking contractors to provide direction in the ongoing refinement of the segment fixing systems. Consequently the following improvements have been made to the T Bolting system:

- A higher compressive force to compress EPDM gaskets
- Bolt head sizes have been rationalised to minimise changes of sockets on air guns
- Bolt washers have been thickened
- Innovative "Ears" have been incorporated onto the T bolt to assist build and alignment

T-Bolt installation system



Sales & technical enquiries
01455 290780
fpmccann.co.uk/tunnels-shafts

“Having used both fixing systems, FP McCann’s T Bolting installation system allows for a faster, more accurate shaft build. The build process is supported by FP McCann’s high level of on-site technical assistance.”

Nick Hctor, Site Agent – DCT Civil Engineering Ltd

“The decision to use FP McCann’s segmental shaft linings is based on a quality finished product incorporating an innovative T Bolting installation system. This results in an overall more efficient, complete shaft building process.”

Dickie Dexter – Director, J Gallagher Contractors

FP McCann offer unrivalled technical and service support and will continue to work closely with customers to improve its products and services.

FP McCann currently offer 3.6m, 4.5m, 5.0m, 6.0m, 7.5m, 8.0m, 9m, 10.5m, 12.5m, 15.0m, 20.0m and 25m ID shaft linings.

