



THINKING PRECAST?
THINK FP MCCANN

AGRICULTURE PRODUCTS QUICK REFERENCE GUIDE





FP McCann is the UK's market leader in the manufacture, supply and delivery of precast concrete solutions. Our comprehensive precast concrete business extends to include:

**AGRICULTURE | ARCHITECTURAL PRECAST
BOX CULVERTS | BUILDING PRODUCTS
DOCK LEVELLERS | DRAINAGE | FENCING
FILTER BEDS | FLOORING | POWER &
INFRASTRUCTURE | RAIL | SPECIALIST PRECAST
STRUCTURAL PRECAST | TANKS & CHAMBERS
TUNNELS & SHAFTS | WALLING**

Modern manufacturing plants at Alnwick (Northumberland), Armagh (Northern Ireland), Byley (Cheshire), Cadeby (Warwickshire), Ellistown (Leicestershire), Grantham (Lincolnshire), Lisnaskea (Northern Ireland), Littleport (Cambridgeshire), Lydney (Gloucestershire), Magherafelt (Northern Ireland), Uddingston (Lanarkshire) and Weston Underwood (Derbyshire) incorporate the latest computerised batching, distribution, casting, curing and handling systems and are operated by skilled and experienced workforces to ensure consistency of quality. Their geographical spread gives us an unrivalled ability to serve the construction industry throughout the UK and Ireland.

By applying the DFMA principles, FP McCann's design engineers are able to evaluate individual precast concrete products part by part, in addition to documenting the assembly process step by step. This allows them to generate the cost, part count and assembly time to provide a benchmark to measure its success and identify the parts and process improvement opportunities. In turn, this has allowed FP McCann to design and manufacture more cost-effective and efficient high-quality precast concrete products with less wastage and greater on-site recycling. As a result, increased productivity, combined with a reduction in production time and costs, allows FP McCann to be more competitive within the marketplace.

Please note: all information is correct at time of going to print.



FP McCann has been supplying the agricultural industry with quality precast concrete solutions for over 60 years. Our agricultural range includes solutions for livestock dairy buildings, bulk storage such as grain, crops, fertiliser, slurry storage and silage. We deliver to any part of the UK and Ireland, meeting your requirements with affordable and safe solutions.

Our valued customer relationships drives FP McCann to develop better products, in addition to adapting existing products to best meet the needs of farmers and farm building contractors. We remain committed to the agricultural community by developing high-quality products that are built to last and can be quickly and easily installed, ensuring on-time delivery.



CONTENTS

Prestressed Precast Panels	4
L Walls	5
T Walls	6
Rocket Walls	7
Easi-Bloc™	8
Cattle Slats	9
Water Troughs	10
Dirty Water/Effluent Tank	11

PRESTRESSED PRECAST PANELS



PRODUCT FEATURES & BENEFITS

- The prestressed panels are all manufactured to BS-EN 1992 standard and are designed in accordance with BS 5502
- Horizontal and vertical panels available
- Quick, easy and efficient installation
- No foundation required for horizontal panels
- Tailor-made lengths and a variety of widths and thicknesses
- Prestressed panels offer superior strength and resilience
- Smooth impervious surface - easily washed down, hygienic solution
- Panels absorb minor accidental damage from livestock
- Cost-effective solution
- Tongue and groove joints for easy alignment and sealing
- Horizontal panels are ideal for supporting against columns of a building or within the flanges of stub columns of an open bunker. The stub columns may be designed to allow the later addition of a roof, or form a building to the outside
- Vertical panels are an effective way of constructing a permanent bunker. Generally double loading panels are available for dividing walls
- Vertical cantilever panels are cast-in to position using cradles prior to construction of the floor slab
- Vertical Cantilever Panels are suitable for use where the situation demands negating any loading onto the frame of an existing structure

The versatility of FP McCann's prestressed concrete panels makes them ideal for creating flexible storage bays of all sizes with a range of thicknesses. Our prestressing process provides enormous strength over a precast panel, making our panels ideal for securely containing grain and other crops.

Dimensions - Horizontal Panel					
Height	1.0m	1.2m	1.5m		
Thickness	80mm	120mm	160mm	200mm	240mm
Length	To suit the project, limited by load/span and handling considerations				

Dimensions - Vertical Panel				
Lengths	To suit the project, limited by load/span and handling considerations			
Thickness	120mm	160mm	200mm	240mm
Widths	1.5m standard, 1m and 1.2m special order			

Note: This product is not manufactured in NI.

L WALLS



PRODUCT FEATURES

- Precast L wall units can be loaded on one side or both sides. They can be placed in bays either sitting near existing walls or using corner units to create a complete L wall system. No steel is required for this option.

APPLICATIONS:

- Silage clamps
- General soil retention
- Division walls
- Retaining walls
- Bunker walls

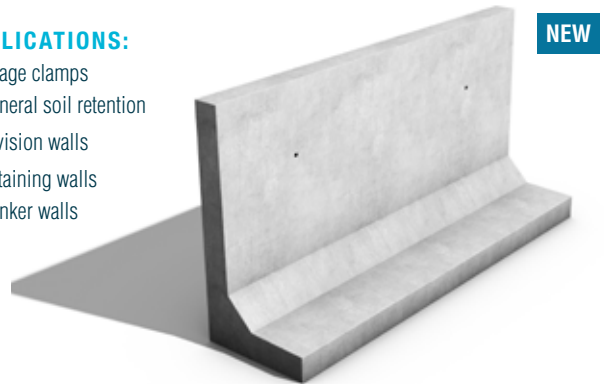

STANDARD L WALL SIZES

The loading 18 kN/m² is approximately a bulk density of 1800 kg/m³

Height (mm)	Width (mm) straight unit	Weight (kg) straight unit	Width (mm) corner unit	Weight corner unit (kg)
1000	1000	440	1000 X 1000	790
NEW 1000	2000	860	1000 X 1000	790
1500	1000	710	1000 X 1000	1170
NEW 1500	2000	1380	1000 X 1000	1170
1750	1000	870	1000 X 1000	1390
2000	1000	1010	1000 X 1000	1580
2500	1000	1500	1250 X 1250	2950
3000	1000	1960	1500 x 1500 (2 Piece)	2350
3750	1000	2950	2310 x 2310 (4 Piece)	2780

(Include 5% lifting allowance)

Similar benefits to T Wall. See overleaf

T WALLS

T wall units are an ideal product where speed of installation is necessary. They offer a fast, cost-effective solution to constructing retaining and containing developments. Standard sizes range from 2m high up to 4m high with a width of 1m for all unit sizes.

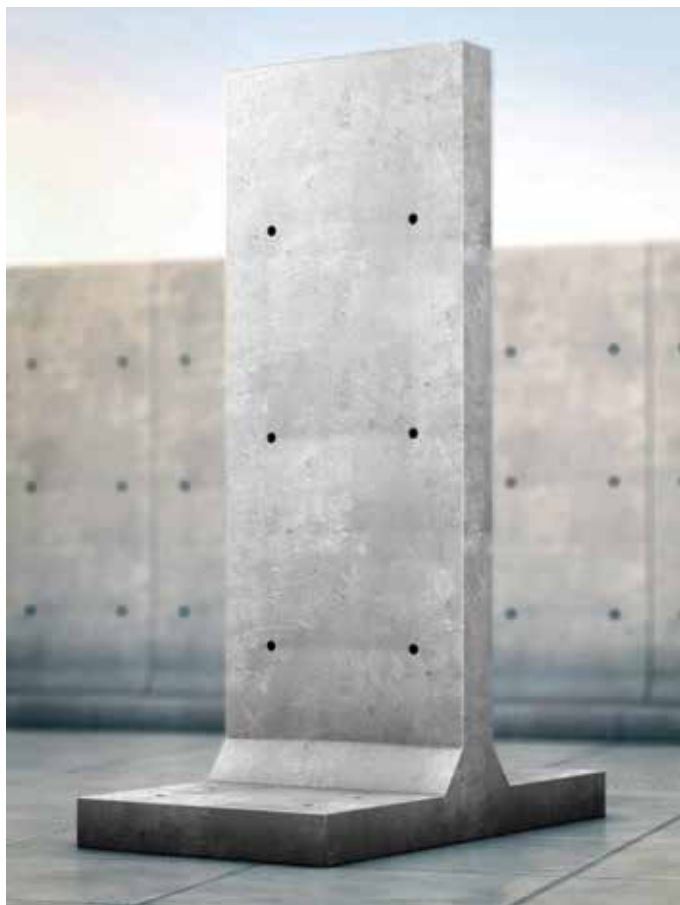

Unit height (mm)	Weight code 1 (kg)	Weight code 2 (kg)
2000	2304	1632
2500	2544	1872
3000	2784	2112
4000	3600	3360

PRODUCT BENEFITS

- Large range of sizes available
- Quick and easy installation
- Create storage bays without imposing a load to the building frame
- Can retain material on both sides
- Retain material up to 18kN/m³

ROCKET WALL

Our Rocket Wall precast unit is an alternative to panels for storing grain and other cereals. These units come in three heights, 2.4m, 3m and 4m and are all the same 1.25m width; by design, these units are freestanding and require no base fixing for level fill grain storage. If surcharged (heaped) grain storage is required, then we recommend that the precast units are bolted to an existing level floor using Excalibur bolts into pre-drilled holes, then grouting over and sealing the joints. Rocket Walls can also be re-sited after the grain has been removed with relative ease, giving the option to reuse the storage area for alternative purposes.

The Rocket Wall units can support up to 16kN/m³ and can be loaded from both sides making them a versatile, fast and effective way to store grain and other cereals. Alternatively, use them to create a dividing wall within a shed to increase storage options.

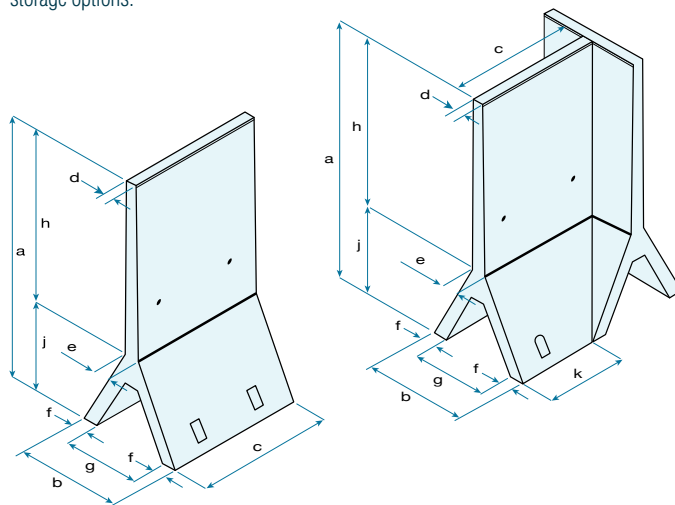

Please note: A-J measurements are in mm.

Dimensions - Rocket Wall (Straight)										
Height (m)	Weight (kg)	a	b	c	d	e	f	g	h	j
2.4	1100	2400	970	1250	100	131	131	710	1600	800
3.0	1860	3000	1200	1250	110	150	165	870	2000	1000
4.0	2820	4000	1650	1250	110	170	185	1280	2600	1400

Dimensions - Rocket Wall (Straight)											
Height (m)	Weight (kg)	a	b	c	d	e	f	g	h	j	k
2.4	1091	2400	970	1200	100	131	131	710	1600	800	759
3.0	1842	3000	1200	1200	110	150	165	870	2000	1000	680
4.0	Steel corner infill assembly										

Please note: A-K measurements are in mm.

EASI-BLOC™



Easi-Bloc™ is a precast concrete block offering solutions where limited space is available for containment. They are simplistic in design, allowing for effortless handling and speed of installation. Easi-Bloc comes in two sizes making them ideal for a variety of applications.

Easi-Bloc contains a central cast-in lifting loop for ease of handling and installation. Products are manufactured to comply with the requirements of BS EN 1992-1-1:2004.



PRODUCT BENEFITS

- Cost-effective
- Interlocking design for easy alignment and added security
- Quick installation
- Durable
- Cast-in lifting pin makes them easy to lift
- Reusable product

APPLICATIONS

- Segregation
- Temporary road blocks
- Agricultural storage bays suitable for grain, silage, etc.
- Earth retention
- Partition walling
- Landscaping
- Retaining wall

Length (mm)	Width (mm)	Height (mm)	Weight (kg)
1200	600	450	750
600	600	450	375
*1400	700	700	1700
*700	700	700	850

* NI only

CATTLE SLATS

FP McCann produces a range of agricultural cattle slats, ideal for use over slurry channels, underground tanks or as part of a suspended floor system.



All cattle slat products are manufactured in accordance with BS 5502 and ISO 9001, ensuring that quality, durability and animal welfare are at the heart of the design and manufacture. The cattle slat products are suitable for use as floors for livestock and are made from high-strength reinforced concrete, designed to withstand the pressure and demands associated with livestock management over a considerable time period. These products are suitable for use with all classes of livestock loading, shown in Table 5 of BS5502: Part 22, including the maximum vehicle loadings.

PRODUCT BENEFITS

- Axle bearing load of 4.5 tonnes
- Edges designed to prevent injury to cattle
- Tapered sides to allow easy access for slurry tank
- Excellent space to surface ratio
- One-man operation for safe mixing or slurry removal from effluent tank
- Hardwearing non-slip surface
- Gang slats
- Cattle and multi-purpose slats available
- Access slat with manhole
- Diagonal slat to cover slurry channels

PRODUCT APPLICATIONS

Cellars / Channels / Dairy farms

GANG AND SAFETY SLAT SIZES

Stock/Nominal Size	8ft/ 2.4m	9ft/ 2.7m	10ft/ 3.0m	11ft/ 3.3m	12ft/ 3.6m	13ft/ 3.9m